

MONTÁŽ

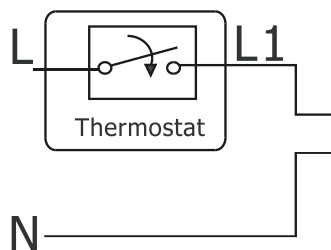

Max. zdvih - 4 mm

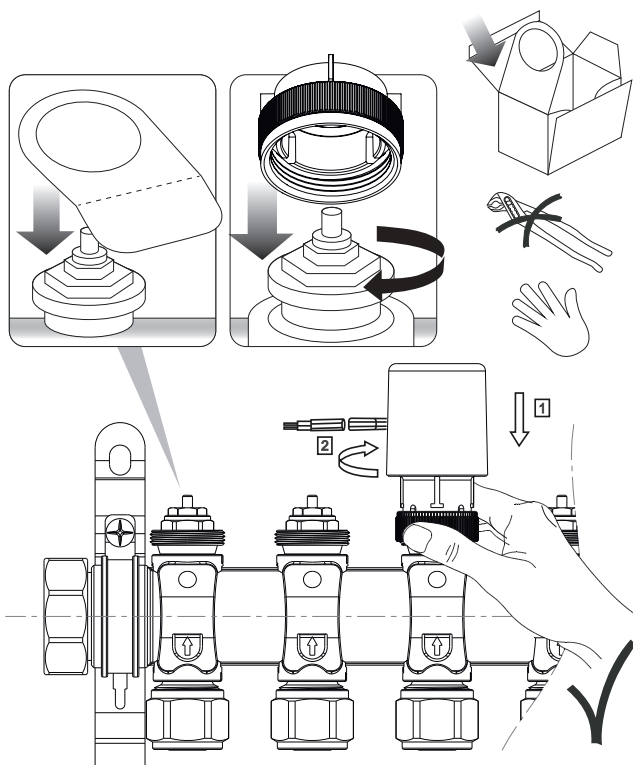
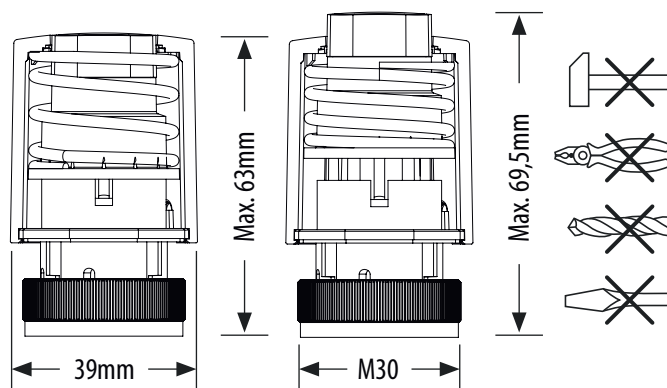

NO - BEZ NAPĚTÍ OTEVŘENÝ

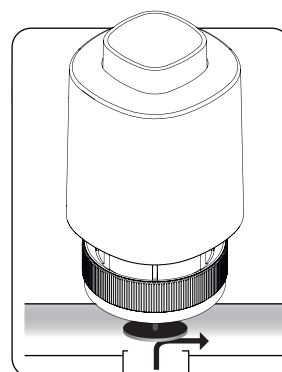

PRINCIP OPERACE

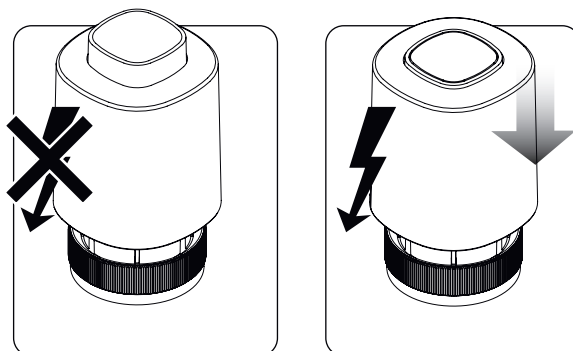

230V

V= 230V
P= 2W
IMAX= 200mA - 200mS
IP54
5-60 °C
F= 100N+10%

24V

V= 24V
P= 2W
IMAX= 250mA - 2 min
IP54
5-60 °C
F= 100N+10%



IMPORTER:
QL CONTROLS Sp. z o.o. Sp. k.
ul. Rolna 4, 43-262 Kobielice

PRODUCER:
Salus Limited
6/F, Building 20E, Phase 3, Hong Kong Science
Park, 20 Science Park East Avenue, Shatin,
New Territories, Hong Kong